

## GTC111-2000

### DYE SUBLIMATION AND FIXATION CALENDER

The GTC111-2000 calender can be used for both dye-sublimation transfer printing (paper to textile) as for dye fixation of direct printed disperse dyes or curing of pigments. With sharp edge definition, high processing speeds, less waste and fewer re-prints, this calender is designed for maximizing your profitability.

The machine is optimized for ease of operation. The position of the textile and papers rolls are well accessible. Tension control for the papers is set by air pressure. Winding of the textile is done on a low tension contact winder, which provides uniformity from the first to the last meter and makes it suitable for all kind of PES textiles. This winder also allows a swift removal of the printed roll without the need for exchanging a shaft!

A touch screen operating panel displays the settings, stores recipes, has a cooling down and programmable start-up-timer, fault indications, but also a very convenient infeed modus; the operator has 3 large control buttons for low-high speed and reverse at the tip of his finger!

It is a typical Klieverik; robust design offering a long life time at low operating cost, the best oil-based heating system for very high temperature consistency and an ingenious belt tracking system for first time right production.

- ▶ Brilliant colours
- ▶ High print definition
- ▶ Reproducibility



# GTC111-2000

## GTC111-2000 TRANSFER PRINTING CALENDER

Transfer printing calender for roll-to-roll transfer printing or fixing of direct printed textile. Working width 1800 mm. The drum is electrically heated with oil as the carrier medium for the highest quality print and reproducible products. The calender is designed for an ergonomic operation.

### CHARACTERISTICS:

- Roller width 2000 mm, working width 1800 mm
- Drum diameter 500 mm
- Mechanical speed 0,4 - 5 m/min
- Textile unwind with low tension from core with cones and roller bearing support
- Adjustable cloth tensioning bar
- Driven low tension textile winder, for winding tension sensitive or stretch textiles. Consisting of:
  - One additional roller for the existing contact winder
  - Frequency controlled electrical drive
  - Differential speed setting +/- for winder; free loop winding possible
- Protection paper unwind and winding position incl. tensioning device and shafts
- Transfer paper unwind and winding position incl. tensioning device and shafts
- Long and high quality Nomex belt
- Stable belt guiding system to prevent movement of the material
- Short heating up time
- Pneumatic brakes
- Touch screen operation, 5.7 inch colour touch screen panel for enhanced machine operation and remote monitoring.

### THE PANNEL OFFERS:

- Recipe creation, storage and retrieval for defined reproducible process settings
- Display of the significant selected parameters
- Remote monitoring from PC/Tablet or Smartphone via Internet connection
- Password protection/operator mode
- Cooling down timer

## TECHNICAL SPECIFICATIONS

### DIMENSIONS / WEIGHT

Machine width	3156 mm/124,3"
Machine length	1484 mm/58,4"
Machine height	1457 mm/57,4"
Machine weight	± 3000 kg

### DIAMETER / WIDHT

Heating cylinder diameter	500 mm/19,7"
Maximum working width	1800 mm/70,9"
Substrate unwind diameter	250 mm/9,8"
Substrate rewind diameter	250 mm/9,8"
Maximum transfer paper width	1800 mm/70,9"
Transfer paper unwind diameter	250 mm/9,8"
Transfer paper rewind diameter	250 mm/9,8"
Maximum protective paper width	1830 mm/72"
Protective paper unwind diameter	400 mm/15,8"
Protective paper rewind diameter	250 mm/9,8"
Internal core diameter	76 mm/3"

### BLANKET

Printing blanket width	2000 mm/78.7"
Printing blanket length	4550 mm/179,1"
Printing blanket thickness	7 mm/0,28"
Arc of contact blanket-cylinder	260°

### TEMPERATURE/SPEED/AIR/PRESSURE/OIL

Maximum temperature	240°C
Mechinal speed	0,4-5 m/min
Air consumption	0,1 Nm <sup>3</sup> /hr
Air	6 bar max./G 1/4"
Maximum linear pressure	-
Oil capacity heating cylinder	215 l.

### ELECTRICAL INFORMATION

Amps req. at 400 VAC input volt (nom.)	59 Amp.
Total power	37 kW
Power heating	36 kW
Voltage	400 V
Number of phases	3ph
Frequency	50 Hz

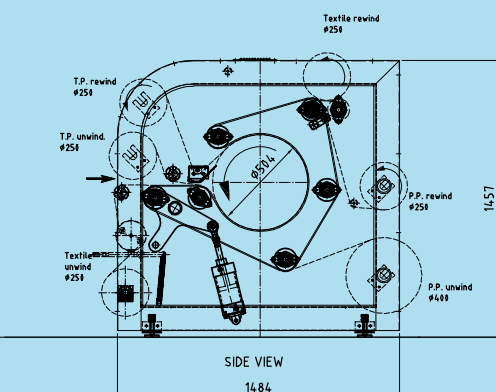
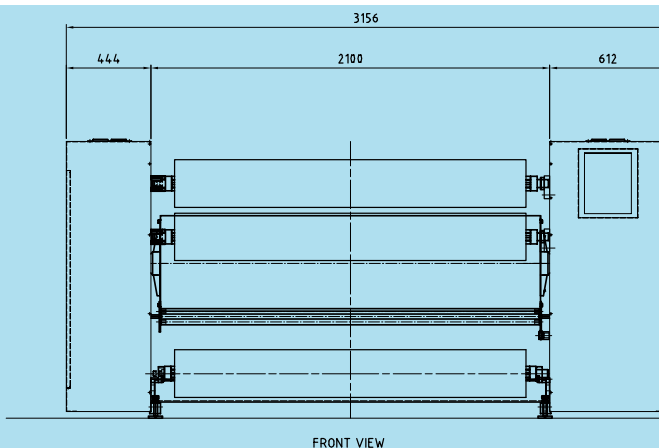

KL\_LFT\_GTC111-2000\_2023.01